



**EN** **User manual**  
Bicycle rack bikelander & bikelander classic

 [westfalia-manuals.com](https://westfalia-manuals.com)

- |           |           |
|-----------|-----------|
| <b>CN</b> | <b>CZ</b> |
| <b>DK</b> | <b>ES</b> |
| <b>FI</b> | <b>FR</b> |
| <b>GR</b> | <b>HU</b> |
| <b>IT</b> | <b>NL</b> |
| <b>NO</b> | <b>PL</b> |
| <b>RU</b> | <b>SE</b> |

**bikelander** 350 050 600 001  
**bikelander classic** 350 053 600 001

## Table of contents

1.	Document information	21
1.1	Validity	21
1.2	Safety instructions	21
1.3	Symbol explanation	21
2.	Safety information	22
2.1	Intended use	22
2.2	Safety instructions on the use of the bicycle rack	22
3.	Product information	24
3.1	Scope of delivery	24
3.2	Accessories	24
3.3	Product overview	25
4.	Putting on the bicycle rack	26
5.	Unfolding the bicycle rack	29
6.	Attaching bicycles	30
7.	Inserting the registration	34
8.	Tilting the bicycle rack	34
9.	Dismantling	35
9.1	Take out the bicycles	35
9.2	Folding together the bicycle rack	35
9.3	Removing the bicycle rack	35
10.	Maintenance and care	36
10.1	Setting the clamping force	36
10.2	Replacing lightbulbs	36
10.3	Bicycle rack care	36
11.	Spare parts	37
12.	Product warranty	37

## 1. Document information

## 1.1 Validity

User manual for:  
bicycle rack bikelander (350 050 600 001) and  
bikelander classic (350 053 600 001)

- Original instructions
- Part of the product
- Copyright reserved
- Reproduction, reprint and distribution with consent only
- Subject to change without notice

## 1.2 Safety instructions

**⚠ WARNING!**

Notes with the word WARNING warn against a dangerous situation that can lead to death or severe injuries.

**⚠ ATTENTION!**

Notes with the word ATTENTION warn against a situation that can lead to slight or moderate injuries.

**⚠ CAUTION!**

Notes with the word CAUTION warn against a situation that can lead to property or environmental damage.

## 1.3 Symbol explanation



Incorrect (e.g. position)



Correct



Acoustic signal (e.g. clicking noise)

▶ Call to action

– List

→ Reference to other sections in this document

☐ Reference to other documents that are to be observed

## 2. Safety information

**⚠ WARNING!**

**Risk of injury with failure to observe the user manual.**

This user manual contains important information on the safe handling of the bicycle rack. Possible dangers are pointed out especially. Failure to observe this can lead to injuries or accidents.

- ▶ Please read the user manual carefully.
- ▶ Follow the safety instructions in this user manual.
- ▶ Keep the user manual in an accessible place.

Use of the bicycle rack is prohibited in the following cases:

- With a damaged bicycle rack.
- With unauthorised modifications or changes.
- For children or persons who cannot assess the dangers of handling the bicycle rack.

In the following cases, the manufacturer will not assume any liability of guarantee with damage:

- With failure to observe this user manual.
- With improper use.
- With incorrect handling.
- With the use of spare parts that are not authorised by the manufacturer.
- With unqualified repair of the bicycle rack.

## 2.1 Intended use

The bicycle rack serves to transport bicycles. The bicycle rack is suitable only for attachment to towing hitches. The range of applications can be expanded through the use of accessories.

Bicycles must meet the following conditions:

- Weight ≤ 30 kg
- Axle spacing of the wheels ≤ 1300 mm
- Width of the tyres ≤ 60 mm
- Frame geometry with standard frame
- Diameter of the frame pipes ≤ 80 mm

The towing hitch must meet the following conditions:

- D-value towball > 6.7 kN
- Material at least S355 (ST52-3) or GJS 520
- Mark of conformity according to 94/20/EC or ECE-R 55
- 12 V connection socket

The bicycle rack is suitable for the use on asphalted roads. Off-road use is not permissible.

Use of the bicycle rack is permissible only with correct attachment and technically accurate condition.

Intended use also includes adherence to the information on the manufacturer sticker and the reading and observing of this user manual.

Any other use is deemed to be improper use.

## 2.2 Safety instructions on the use of the bicycle rack

In traffic, the driver is responsible for the safety of the vehicle and its load.

The country-specific laws for load restraint prevail and must always be observed (e.g. labelling requirements with a warning panel).

The following values must be observed for the attachment of the bicycles:

- Maximum bearing load of the bicycle rack of 60 kg.
- Maximum tongue weight of the towing hitch.
- Permissible axial load of the vehicle.
- Permissible total weight of the vehicle.

- Please refer to the instructions for your vehicle and/or the manufacturer sticker on the towing hitch for information on tongue weight, axial load and total weight.

## Before driving

The following points must be checked before driving if you are using the bicycle rack:

- Correct attachment of the bicycle rack to the vehicle.
- Correct attachment of the bicycles.
- No covering of the bicycles through protective covers.
- Folding out of all components on the bicycle rack.
- Locking of all locks.
- Attachment of a registration marks matching the registration on the vehicle.
- Function of the lights on the bicycle rack (tail light, brake lamp, turn signal, rear fog light\*, number plate lamp).
- Cover of the reflectors on the bicycles during night drives.
- Unobstructed view of the lights and the registration of the bicycle rack from the rear.
- Unobstructed view of the drives in all directions.
- If the load extends more than 400 mm past the light clamp on the side, the load must be marked as follows:
  - With a white light to the front.
  - With a red light to the rear.
  - Max. 1500 mm above the lane.
- If the rear fog light is used on the bicycle rack, the rear fog light on the vehicle must be deactivated.
- If a third brake light on the vehicle is covered by the bicycles, a third replacement brake lamp must be attached.
- In order to reduce the tail heaviness, heavy loads in the boot must be placed as far up front as possible.
- With drives without bicycle, the spacers of the bicycle rack must be dismantled.

If no bicycles are transported, we recommend: Taking the bicycle rack off the towing hitch and transporting it in the boot, for instance. This can reduce fuel consumption, facilitate parking and spare the bicycle rack.

\*If the vehicle is equipped with a rear fog lamp and this results in defects or error messages, remove the bulb in the 2nd rear fog lamp on the bicycle rack on the passenger side<sup>0</sup>

## During the drive

The following points must be observed while driving with the bicycle rack:

- Check the load situation regularly by looking into the rear-view mirror.
  - If the load situation changes, you must drive to the next possible stop at a reduced speed to check the attachment.
  - Do not exceed a speed of 130 km/h.
  - Increased side wind sensitivity must be expected due to the larger side area.
  - A change in braking behaviour must be expected due to the changed load distribution.
  - Do not drive off road.
  - Do not drive into a car wash.
  - Check the correct seat of the bicycle rack and the attachment of the bicycles approx. 10 km after starting the drive.
  - During longer drives, check the correct seat of the bicycle rack and the attachment of the bicycles every 500 km. Check at appropriate earlier intervals with uneven roads.
  - Allocation of the socket on the towing hitch can automatically deactivate assistance systems (e.g. parking sensor, parking assistant, automatic boot lid).
- Please refer to the instructions of your vehicle for information on assistance systems.

### 3. Product information

#### 3.1 Scope of delivery

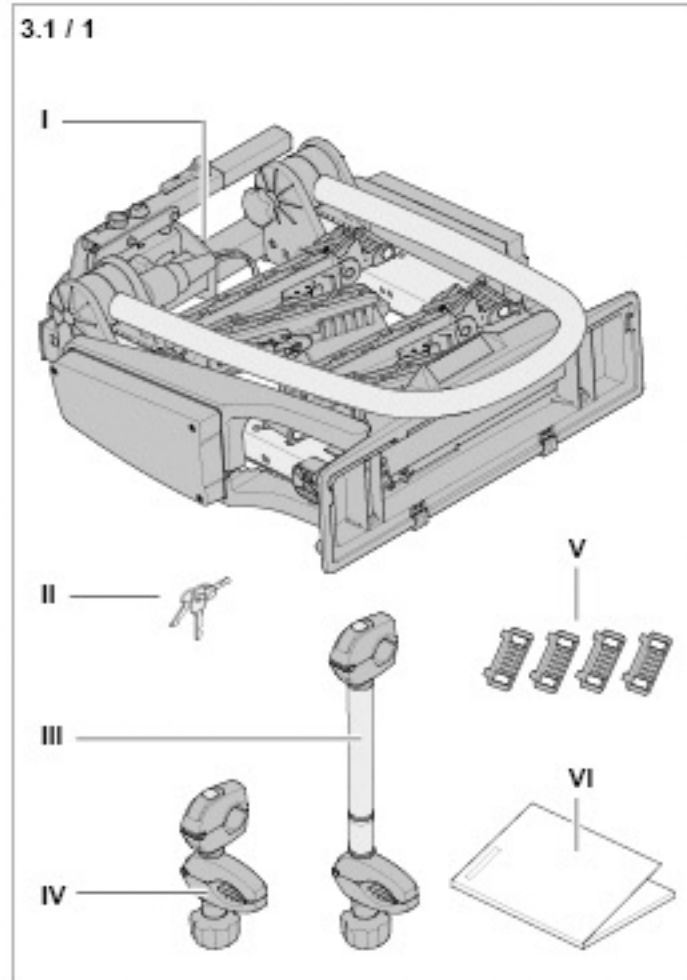

I a	Bicycle rack bikelander
I b	Bicycle rack bikelander classic
II	Key
III	Long spacer
IV	Short spacer
V	Wheel rim protector
VI	User manual

► Check the scope of delivery for completeness.

#### 3.2 Accessories

	<b>Transport box</b> 350 002 600 001
	<b>Transport platform</b> 350 004 600 001
	<b>Extension rail for a 3rd bicycle</b> 350 055 600 001
	<b>Loading ramp</b> 350 020 600 001
	<b>Transport bag</b> 350 013 600 001
	<b>Wall holder</b> 350 008 600 001
	<b>Additional brake light</b> 350 000 305 173

#### 3.3 Product overview

3.3 / 1

**G**

westfalia  
AUTOMOTIVE  
Westfalia-Automotive GmbH  
www.westfalia-automotive.com

TYPE: MCU CHARGE: \_\_\_\_\_

**E13** 26R - 03 8433

VERTICAL LOAD S: LOAD:  $m = 17,2 \text{ kg}$

50 kg → 32,6 kg  
85 kg → 60 kg

max. 30 kg  
130 km/h

A	Tommy nut for spacers
B	Mounting bracket clamp
C	Bicycle clamp
D	Spacer lock
E	Mounting bracket
F	Clamping lever
G	Manufacturer sticker
H	Plug
I	Star knob for the mounting bracket
J	Wheel support
K	Wheel support lock
L	Wheel rail
M	Drive belt unlocking mechanism
N	Drive belt lock
O	Plug holder
P	Clamping lever lock
Q	Clamping lever locking mechanism
R	Adjusting screw
S	Drive belt
T	Wheel rim protector
U	Light clamp
V	Registration holder
W	Registration clamp
X	Tilt protection
Y	Tilting lever
Z	Wheel rail lock

4. Putting on the bicycle rack

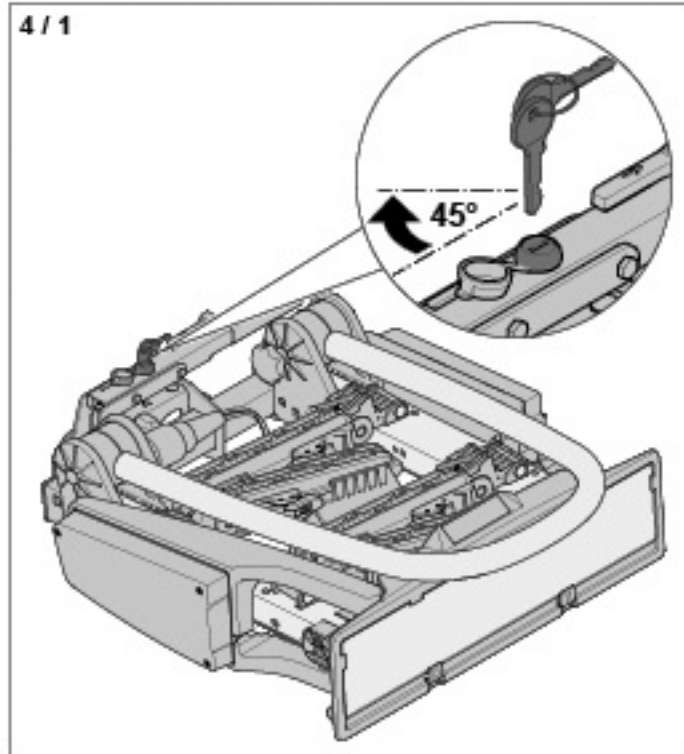

► Unlock the clamping lever lock.

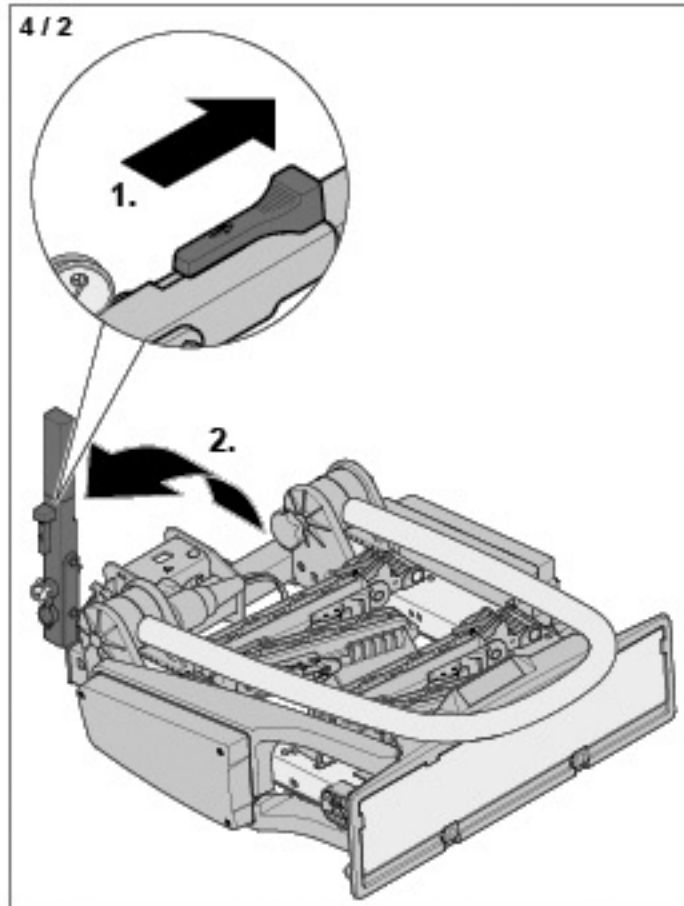

► Unlock the clamping lever (1).  
► Pull up the clamping lever (2).

The towing hitch must be suitable for bicycle rack attachment.  
→ „2.1 Intended use“ on page 22

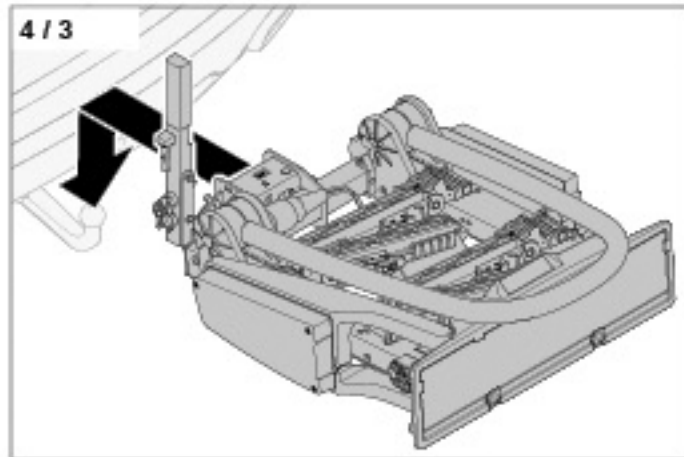

► Put the bicycle rack on the vehicle's towing hitch.

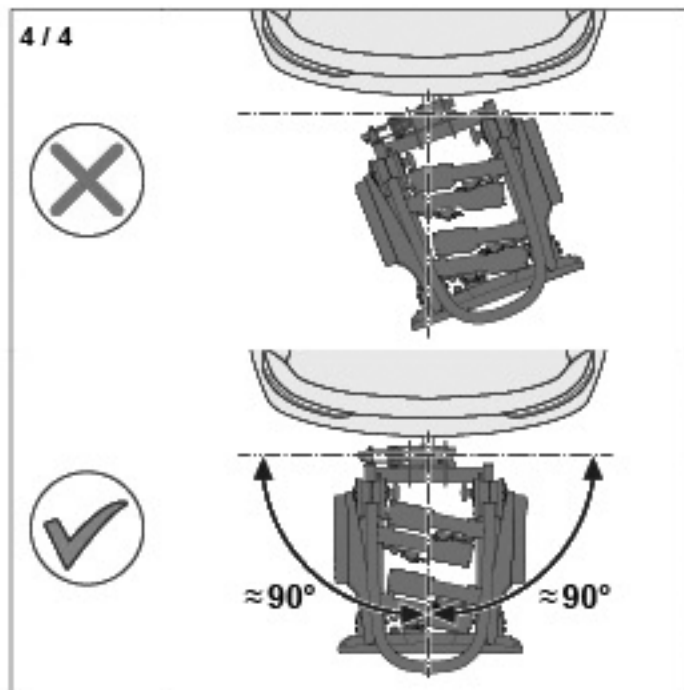

► Align the bicycle rack laterally.

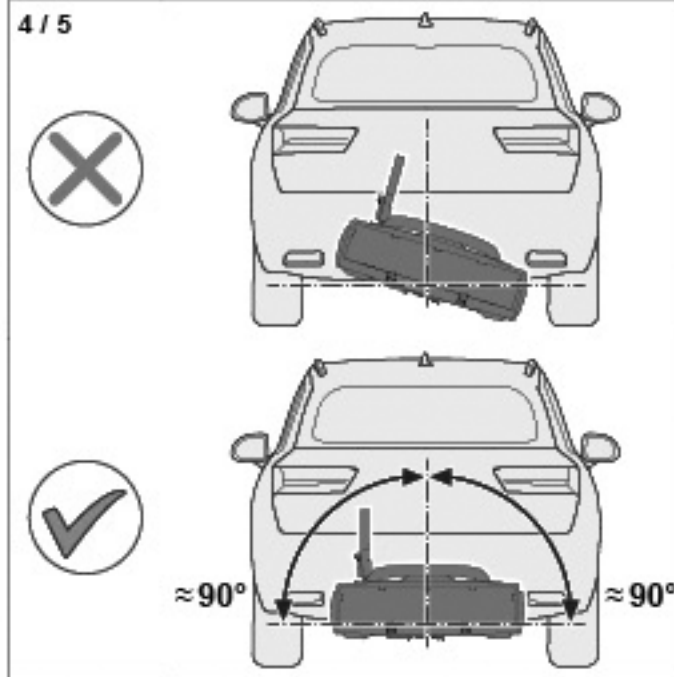

► Align the bicycle rack horizontally.

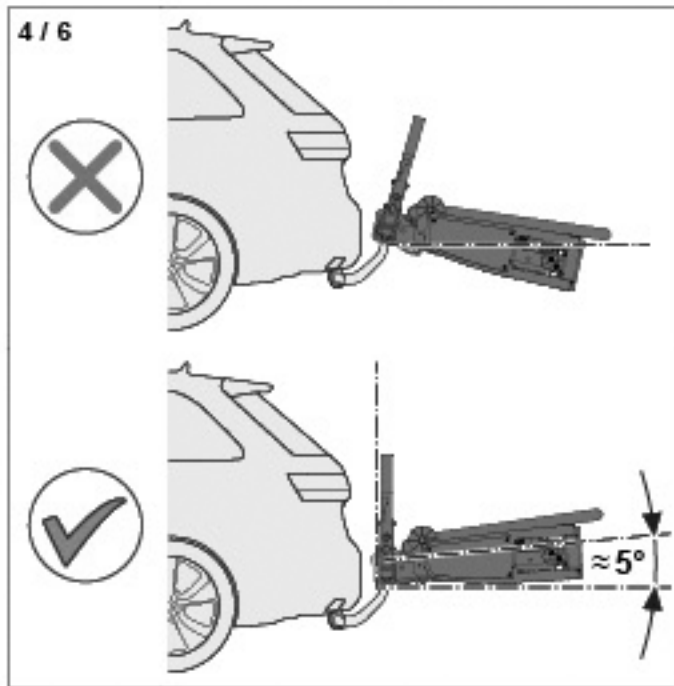

► Align the bicycle rack vertically.

The bicycle rack is clamped onto the towing hitch. The clamping force of the bicycle rack is factory-set so that the clamping lever must be pushed down with a force that complies with a weight of 35–45 kg.

Check the clamping force during the first use. The required clamping force can differ with older or worn towing hitches.  
→ „10.1 Setting the clamping force“ on page 38

**WARNING!**

Danger of accidents from faulty clamping of the bicycle rack.  
A too low clamping force can lead to the bicycle rack twisting on the towing hitch during the drive.  
► Ensure that the towball and its contact surfaces are clean and free from grease.  
► Always push the clamping lever all the way down to the stop with the required force.  
► Ensure that the red mark on the clamping lever lock is not visible.

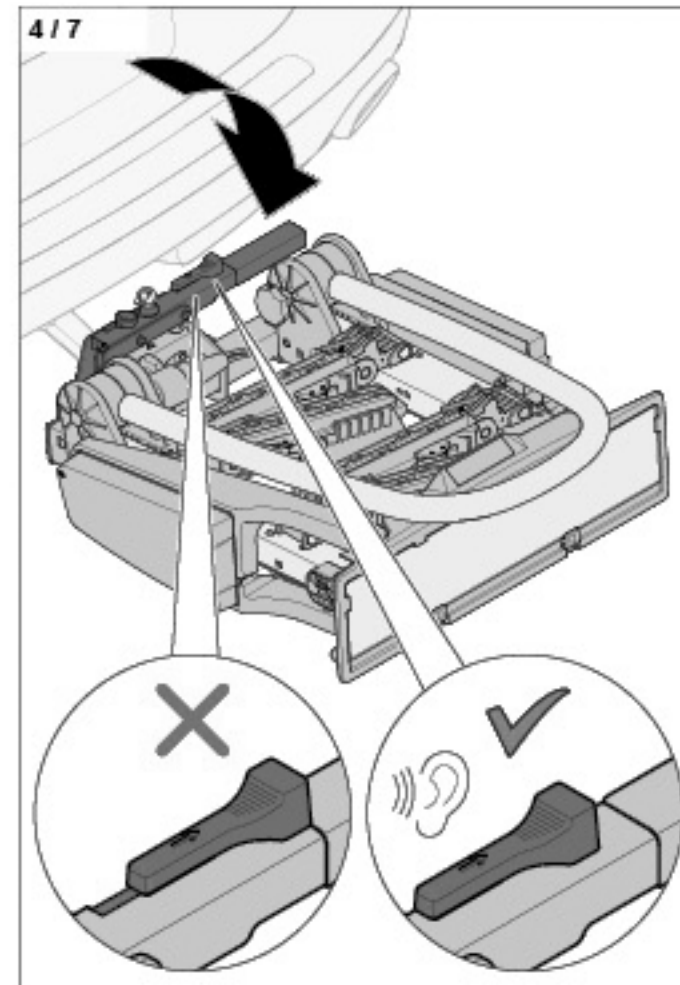

► Push the clamping lever with a force that complies with a weight of 35–45 kg down until it engages.

If the clamping lever cannot be pushed down to the stop:  
► Pull the clamping lever back up.  
► Raise the rear of the bicycle rack and move up the vertical alignment.  
→ Fig. „4 / 6“  
► Push down the clamping lever all the way to the stop.

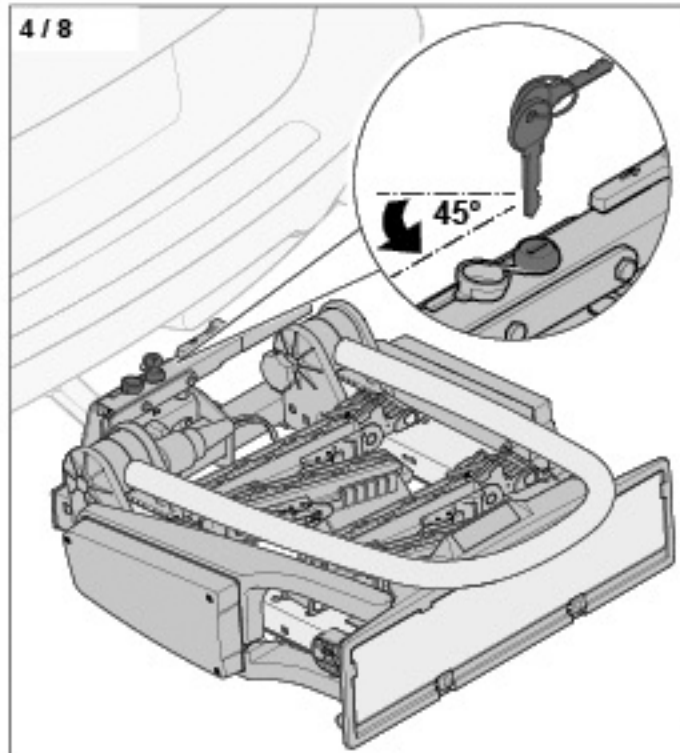

- ▶ Lock the clamping lever lock.
- ▶ Pull out the key.

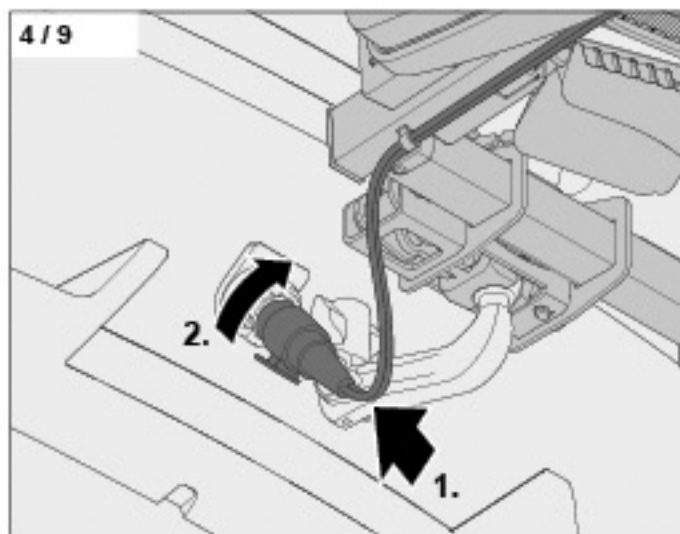

- ▶ Put the plug into the bushing on the towing hitch (1).
- ▶ Rotate the plug in the bushing clockwise until it engages (2).

**CAUTION!**

Danger of damage to the cable.  
The cable can be damaged by the heat of the exhaust fumes or by dragging on the road. The function of the lights is then no longer guaranteed.  
▶ Mind the correct laying of the cables.

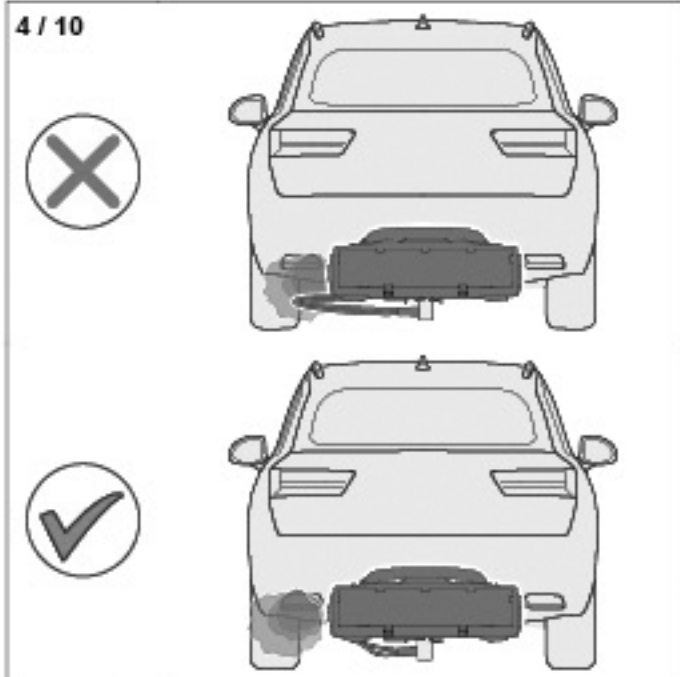

- ▶ Keep the cable away from the exhaust.

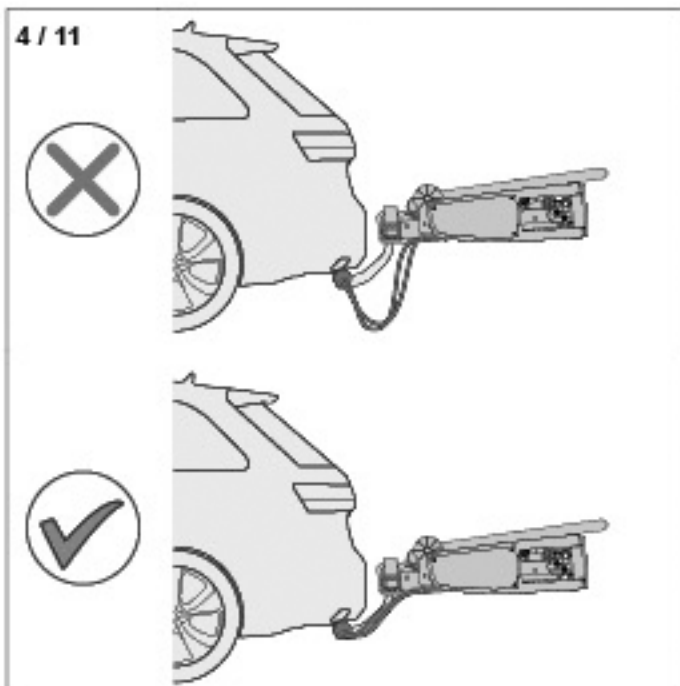

- ▶ Keep the cable away from the road.

5. Unfolding the bicycle rack

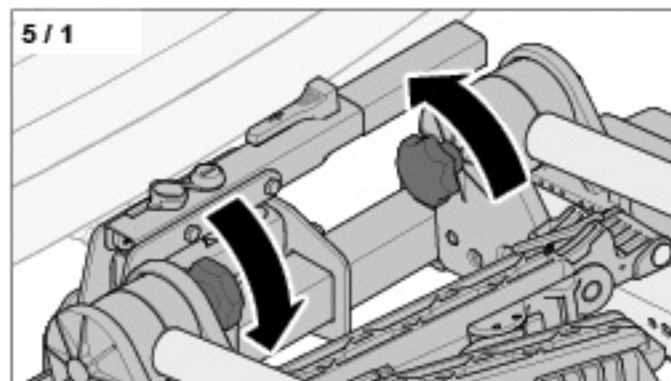

- ▶ Loosen the two star knobs for the mounting bracket.

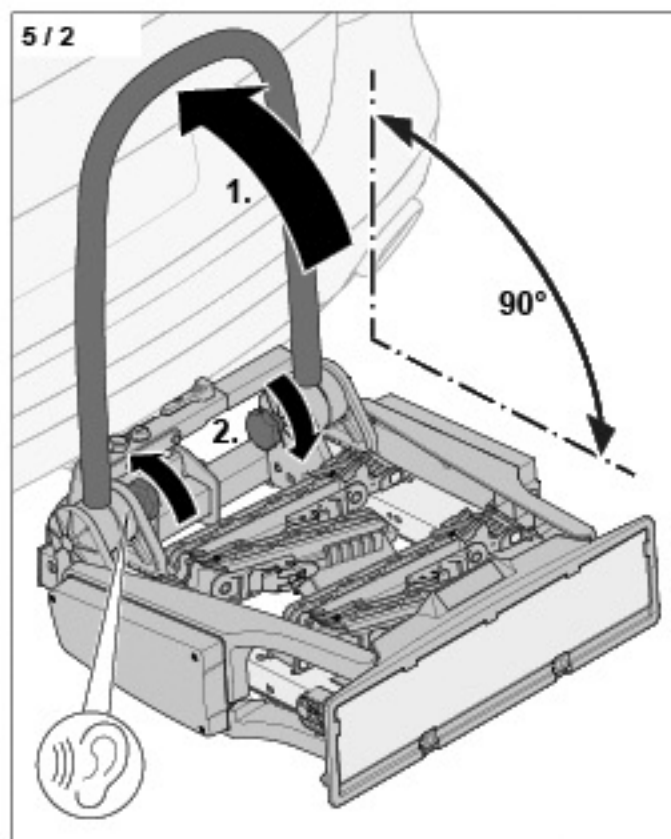

- ▶ Flip up the mounting bracket (1).
- ▶ Tighten both star knobs for the mounting bracket (2).

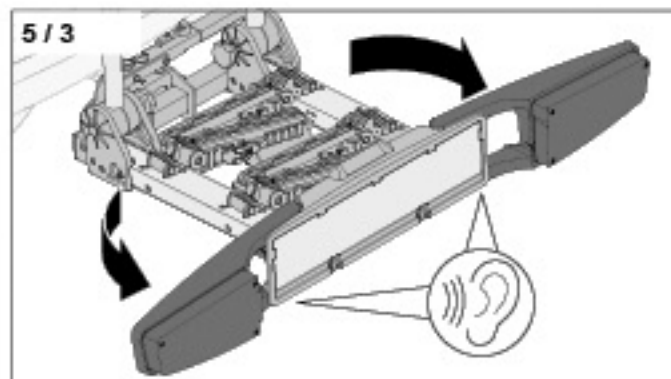

- ▶ Fold out both light clamps until they engage.

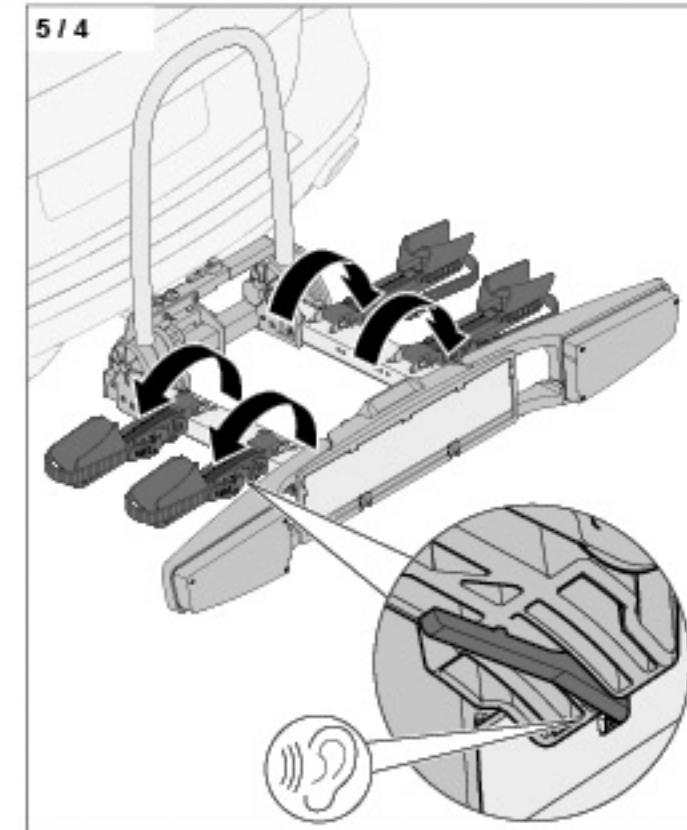

- ▶ Fold out all wheel supports until they engage.

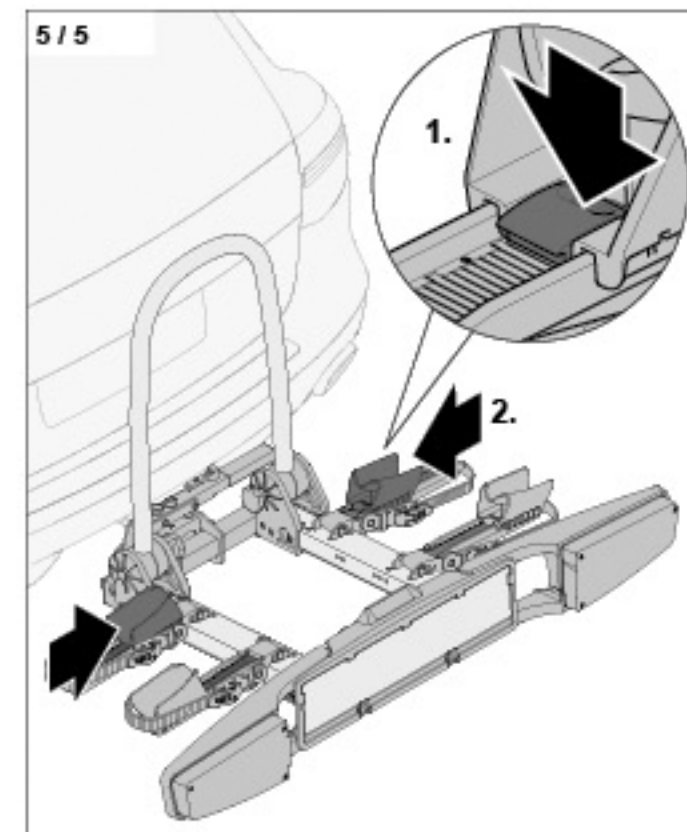

- ▶ Push the wheel support lock (1).
- ▶ Push in the wheel supports all the way (2).

6. Attaching bicycles

The bicycles must be suitable for attachment to the bicycle rack.

→ „2.1 Intended use“ on page 22

The permissible tongue weight of the towing hitch must not be exceeded.

▶ Please refer to the instructions of your vehicle for the permissible tongue weight.

The tongue weight working on the towing hitch is calculated as follows:

Bicycle rack (17.2 kg) + bicycle 1 + bicycle 2

**WARNING!**

Danger of accidents through the loss of parts.

Loose parts or additional attachments to the bicycles can loosen and fall off during the drive.

▶ Remove all loose parts and additional attachments to the bicycles (e.g. drinking bottles, bungee cords, saddlebags, baskets, rechargeable batteries, infant seats...)

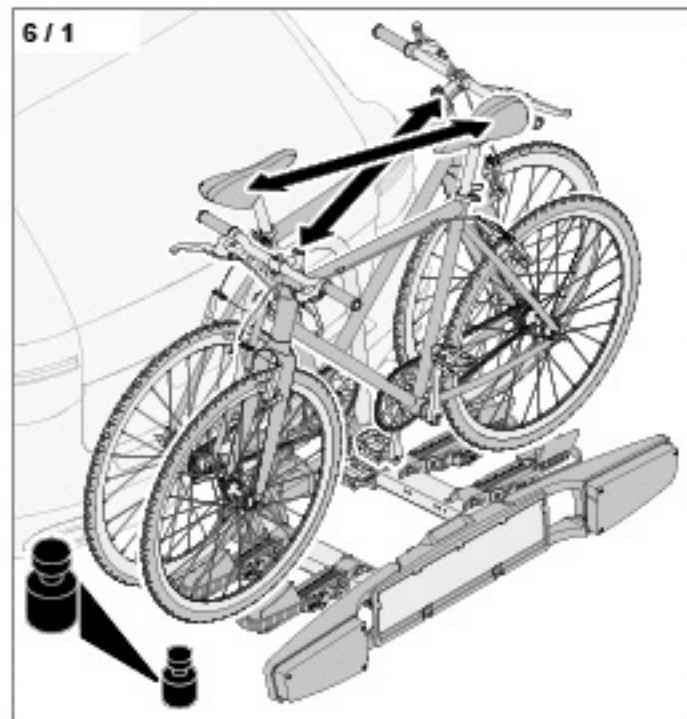

Correct arrangement of the bicycles:

- Two bicycles must be mounted in opposite directions.
- The bicycle with the greater weight must be mounted close to the vehicle.
- If you are transporting only one bicycle, it must be mounted close to the vehicle.

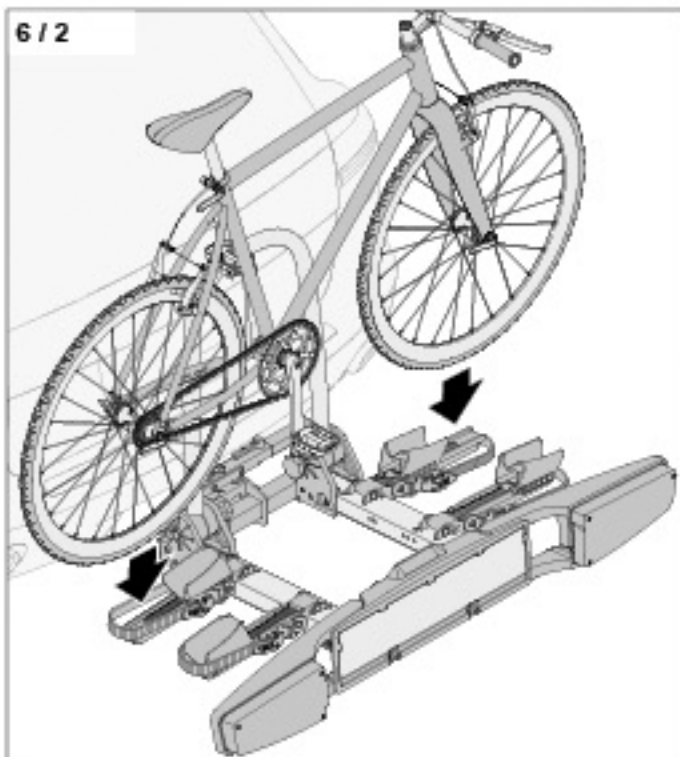

▶ Put the bicycle on the wheel rails.

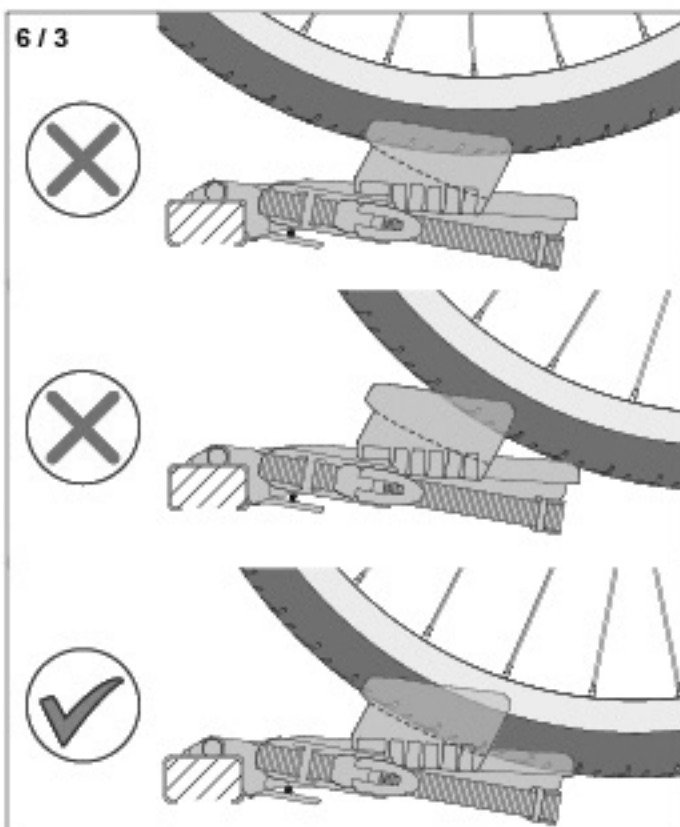

▶ Push the wheel supports up to the bicycle.

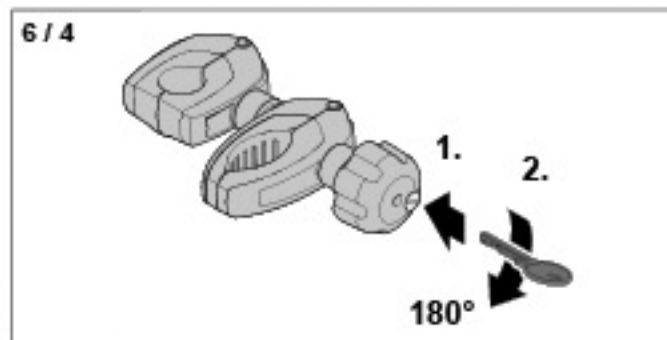

- ▶ Put the key into the spacer lock (1).
- ▶ Open the spacer lock (2).

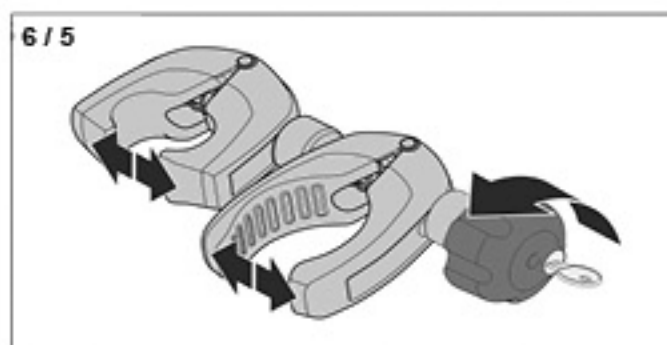

▶ Open the clamp by rotating the tommy nut.

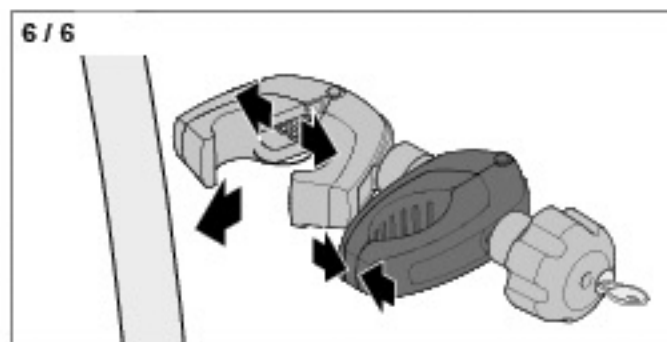

▶ Press the bicycle clamp together to be able to open the bracket clamp.

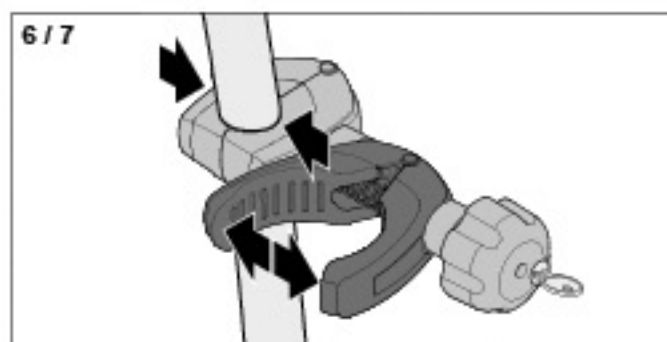

▶ Attach the bracket clamp to the bracket by opening or pulling apart and spreading the bicycle clamp.

**CAUTION!**

Danger of property damage to the bicycle. Sensitive components (e.g. shift and brake cables, carbon frames) can be damaged from clamping with the spacer.

- ▶ Ensure that the bicycle frame is suitable for attachment.
- ▶ Attach the bicycle clamp only on the bicycle frame or on the saddle tube.

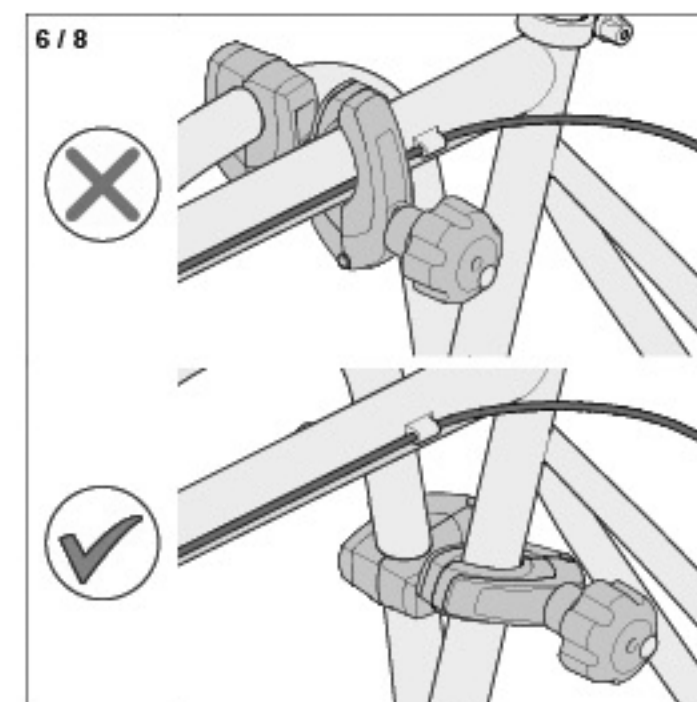

▶ Select the position for safe bicycle attachment.

**WARNING!**

Danger of accidents from faulty fixation of the bicycles.  
 If the spacer is not attached properly, the bicycle can topple over or fall off.  
 ► Ensure that the bicycle clamp is aligned with the mounting bracket.  
 ► Ensure that the bicycle clamp is aligned with the frame.  
 ► Replace defective clamps immediately.

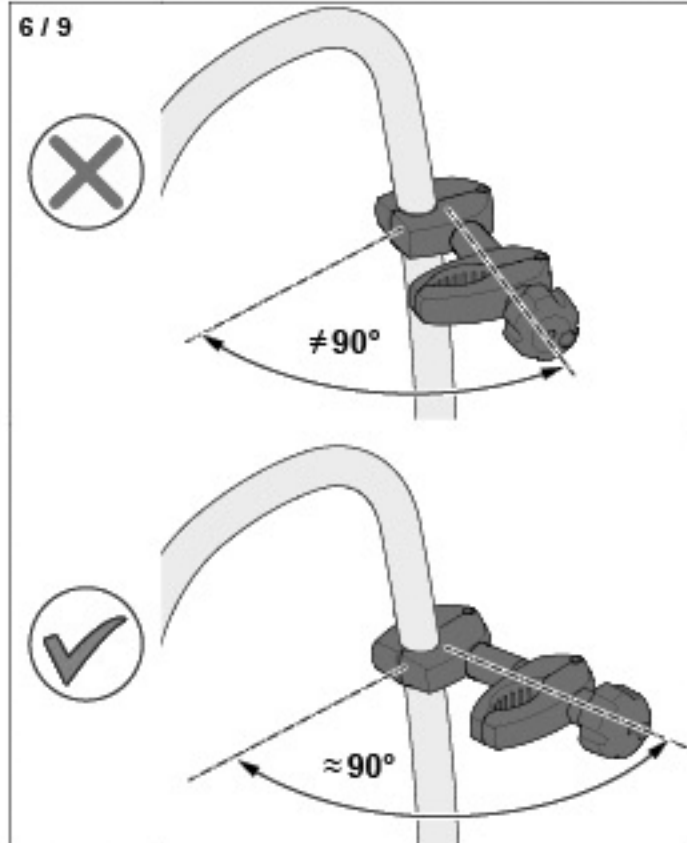

► Align the spacer with the mounting bracket.

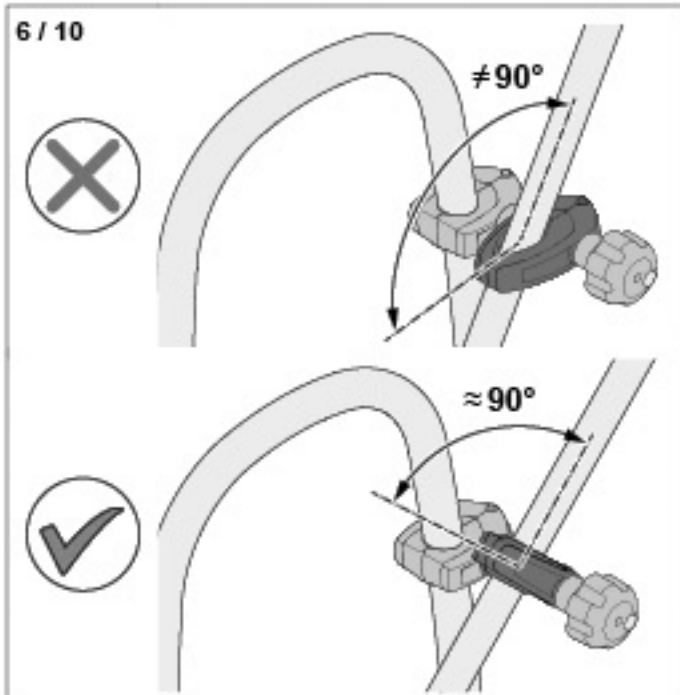

► Put the bicycle clamp around the bicycle frame.  
 ► Align the bicycle clamp with the frame.

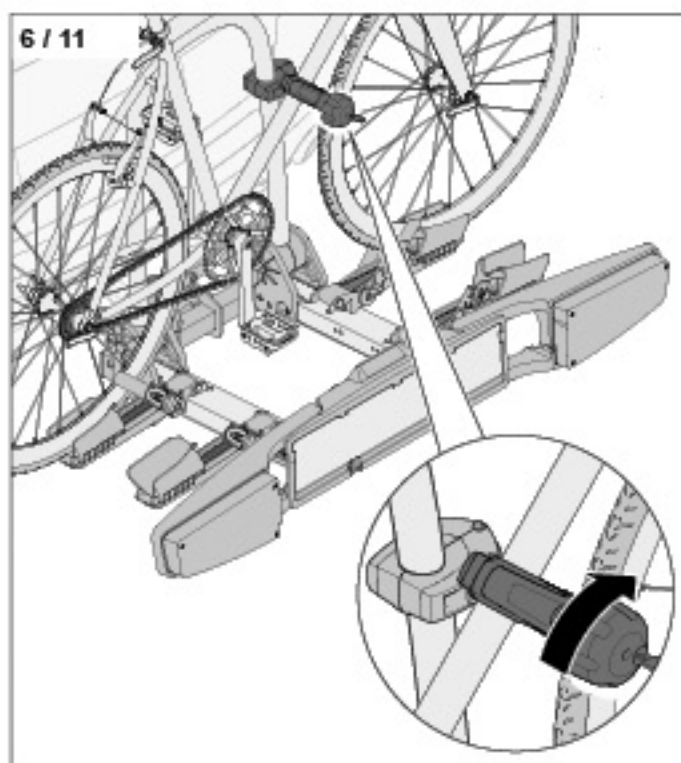

► Turn the tommy nut to attach the bicycle with the bicycle clamp.

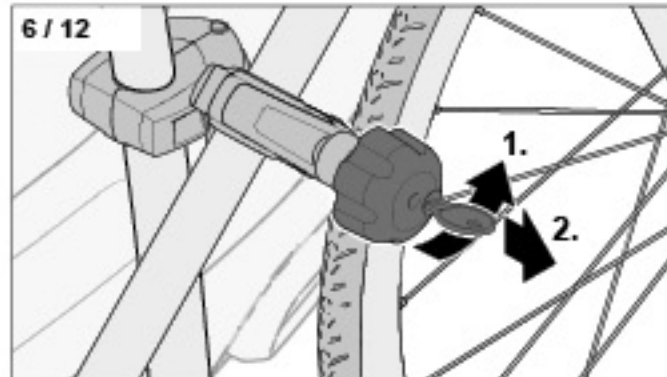

► Close the spacer lock (1).  
 ► Pull out the key (2).

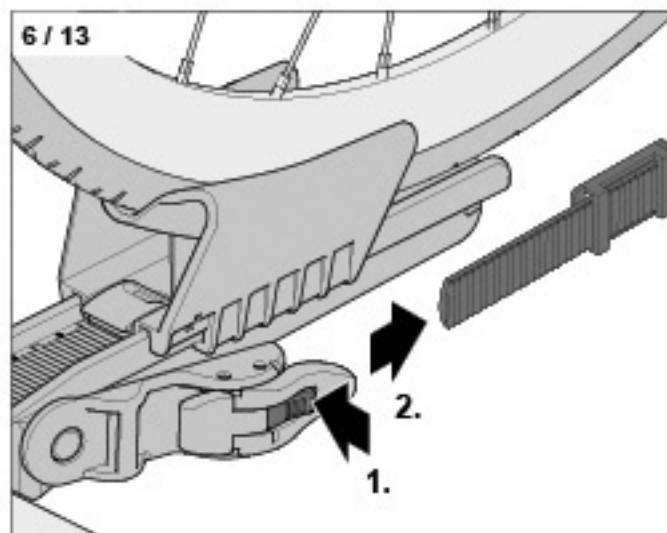

► Push the drive belt unlocking mechanism (1).  
 ► Pull the drive belt out of the drive belt lock (2).

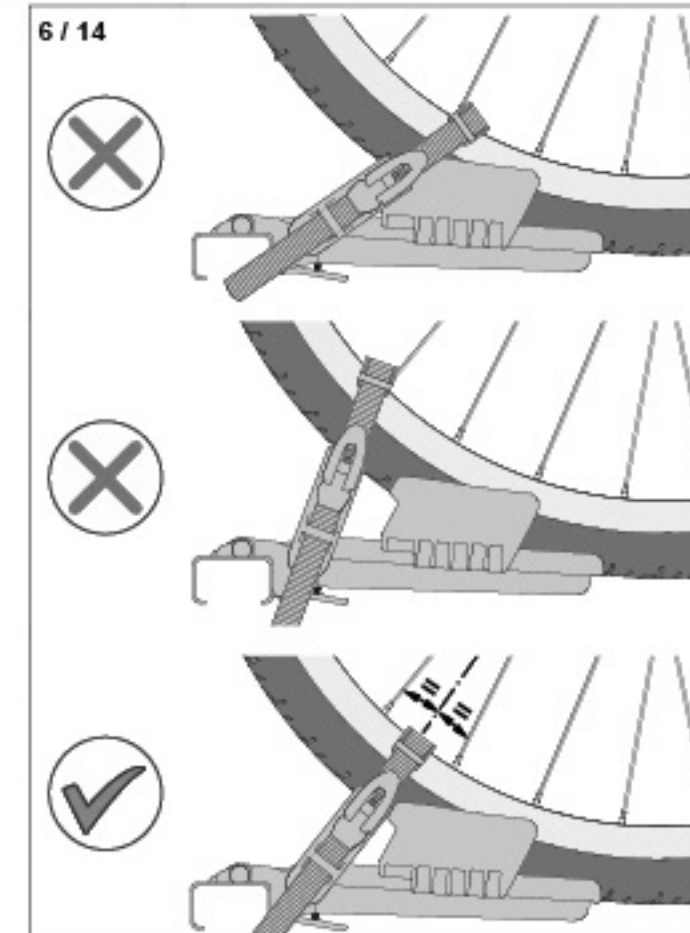

► Place the drive belt on both sides above the wheel rim.

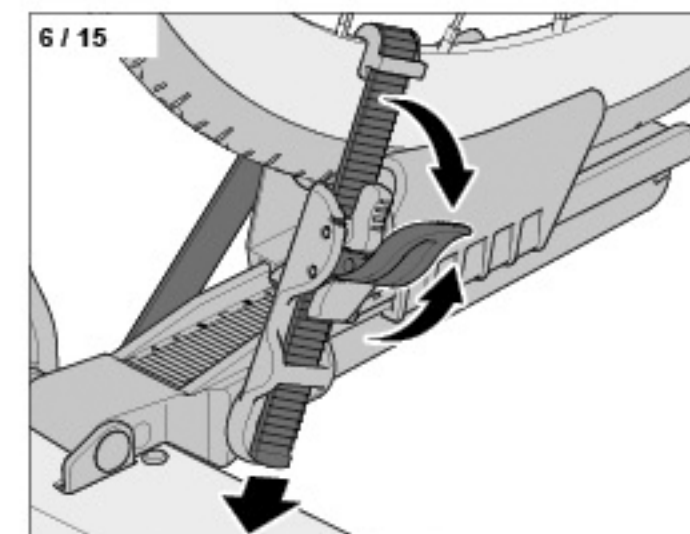

► Put the wheel rim protector on the wheel rim.  
 ► Insert the drive belt in the drive belt lock.  
 ► Tension the drive belt with repeated up and down movements of the drive belt lock.

Attach additional bicycles with the same procedure.



## 7. Inserting the registration

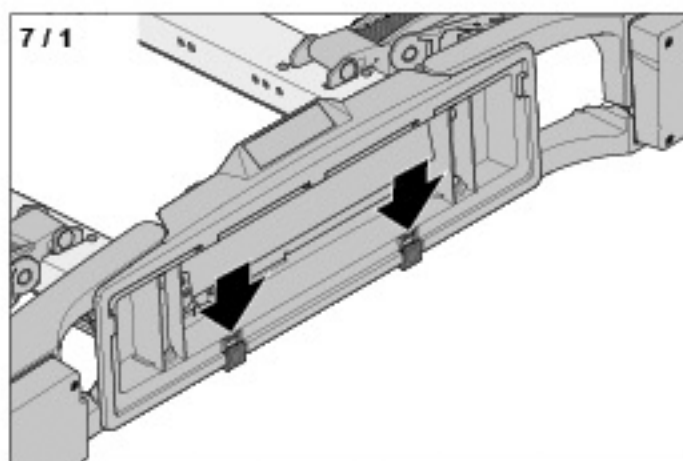

- ▶ Ensure that the registration clamps are pushed down.

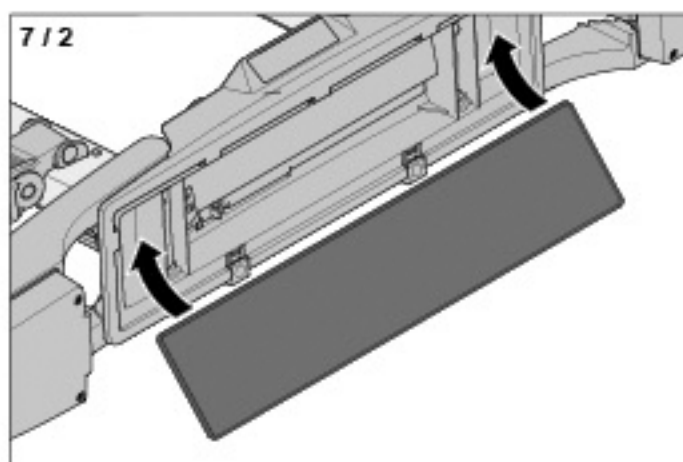

- ▶ Insert the registration in the registration holder.

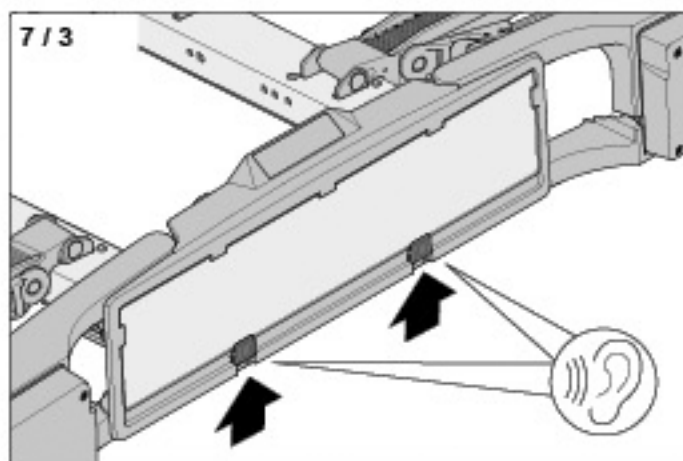

- ▶ Push the registration holder up (confirmed with 2 or 3 clicking sounds).
- ▶ Ensure that the registration is fixed in place.

## 8. Tilting the bicycle rack

Access to the vehicle boot is possible also with mounted bicycles. The bicycle rack has a tilting function that enables opening the boot lid.

Tilting down the bicycle rack

### ⚠ CAUTION!

Danger of property damage to the bicycle. Broad handlebars can touch the road when the system is tilted down.

- ▶ Tilt the bicycle rack down slowly and carefully.

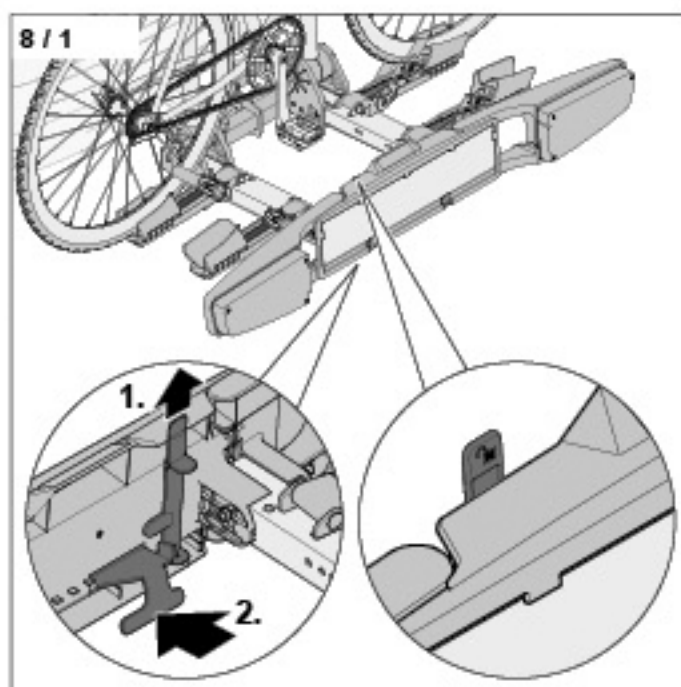

- ▶ Pull up the tilt protection (1).
- ▶ Grab the tilting lever from the bottom.
- ▶ Pull the tilting lever (2).

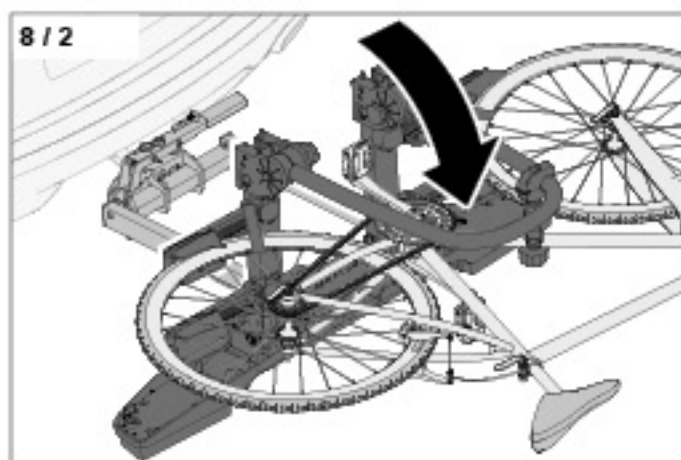

- ▶ Tilt the bicycle rack away from the vehicle.

The boot can now be opened.

Setting the bicycle rack upright

### ⚠ CAUTION!

Danger of property damage to the vehicle. When the boot lid is open, the bicycles can hit the boot lid during the uprighting movement.

- ▶ Close the boot lid before uprighting the bicycle rack.

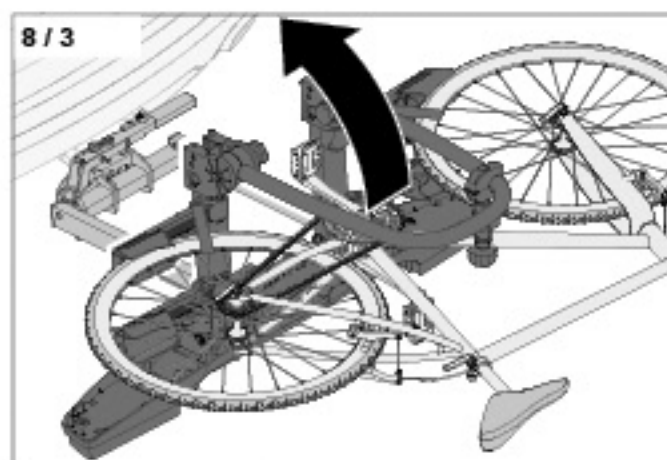

- ▶ Set the bicycle rack upright.

### ⚠ WARNING!

Danger of accidents from unsecured tilting levers. Driving with an unsecured tilting lever can trigger the tilting function during the drive.

- ▶ After uprighting the bicycle rack, check whether it is firmly latched into place.
- ▶ Secure the tilting lever with the tilt protection.

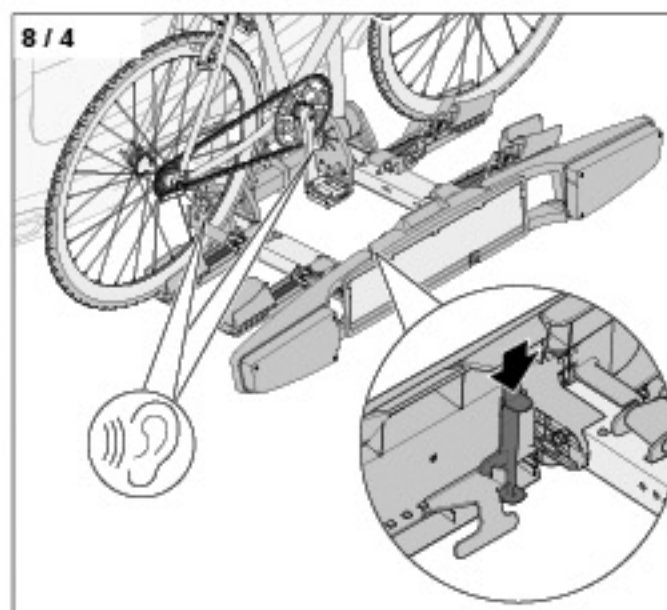

- ▶ Push down the tilt protection.

## 9. Dismantling

### 9.1 Take out the bicycles

- ▶ Unlock the spacer lock.
- ▶ Rotate the tommy nut counter-clockwise to open the bicycle clamp.
- ▶ Push the drive belt unlocking mechanism to loosen the drive belt.
- ▶ Pull the drive belt out of the drive belt lock.
- ▶ Take the bicycles off the bicycle rack.
- ▶ Remove the spacers.

### 9.2 Folding together the bicycle rack

- ▶ Put the drive belt around the wheel supports.
- ▶ Insert the drive belts in the drive belt lock.
- ▶ Push up the wheel rail lock.
- ▶ Fold in the wheel rails.
- ▶ Fold in the light clamps.
- ▶ Loosen the star knobs for the mounting bracket.
- ▶ Rotate the mounting bracket down.
- ▶ Tighten the star knobs for the mounting bracket.

### 9.3 Removing the bicycle rack

- ▶ Rotate the plug in the socket against counter-clockwise.
- ▶ Pull the plug out of the socket.
- ▶ Push the plug into the plug holder.
- ▶ Unlock the clamping lever locking mechanism.
- ▶ Unlatch the clamping lever.
- ▶ Pull up the clamping lever.
- ▶ Take off the bicycle rack.
- ▶ Push down the clamping lever.
- ▶ Lock the clamping lever locking mechanism.

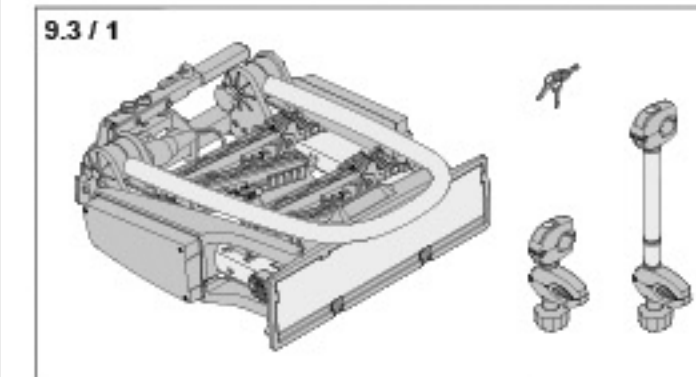

## 10. Maintenance and care

### 10.1 Setting the clamping force

Check the clamping force during the first use. The required clamping force can differ with older or worn towing hitches.

The clamping force of the bicycle rack is sufficient if the clamping lever can be pushed down with a force that complies with a weight of 35–45 kg during the clamping of the bicycle rack to the towing hitch.

The clamping force can be increased or reduced with the help of the adjusting screw.

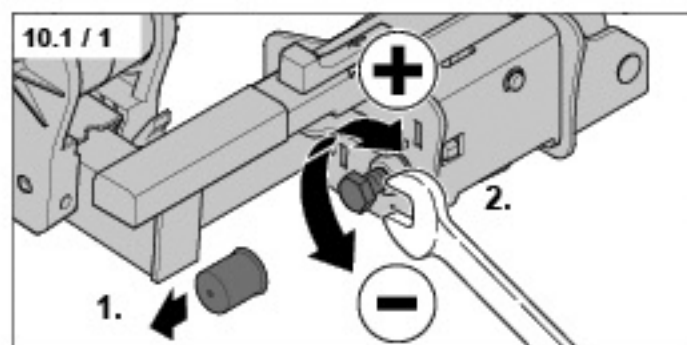

- ▶ Take off the cover (1).
- ▶ Set the clamping force correctly (2).
- ▶ Put the cover back on.

After setting the clamping force:

- ▶ Push down the clamping lever all the way to the stop until it engages.  
→ Fig. 4 / 7"
- ▶ Check the firm seat of the bicycle rack on the towball, e.g. by rotating it to the side.

If the bicycle rack can be moved manually, the clamping force must be increased. If necessary, the clamping force setting can be checked by a specialist workshop.

### 10.2 Replacing lightbulbs

- ▶ Contact a specialist retailer or specialist workshop for lightbulb replacements.

### 10.3 Bicycle rack care

#### ⚠ WARNING!

**Danger of accidents from a loosening or slipping of the bicycle rack.**

The greased contact surfaces for the towball holder or the lubricated screw connection can loosen the attachment. The bicycle rack or the bicycles can slip or fall off.

- ▶ Ensure that the towball contact surfaces are clean and free from grease.
- ▶ Never lubricate or grease screw connections.

#### ⚠ CAUTION!

**Danger of damage from incorrect cleaning.**

High-pressure cleaners, scouring agents or aggressive cleaning agents can damage the bicycle rack.

- ▶ Clean the bicycle rack with water and car shampoo.

Care for the bicycle rack as follows:

- ▶ Regularly clean the bicycle rack.
- ▶ Remove salt and dirt after using it in the winter.
- ▶ Spray the lock with resin-free oil after 100 locking cycles; however, at least every 2 months. After that, operate the locks several times.

## 11. Spare parts

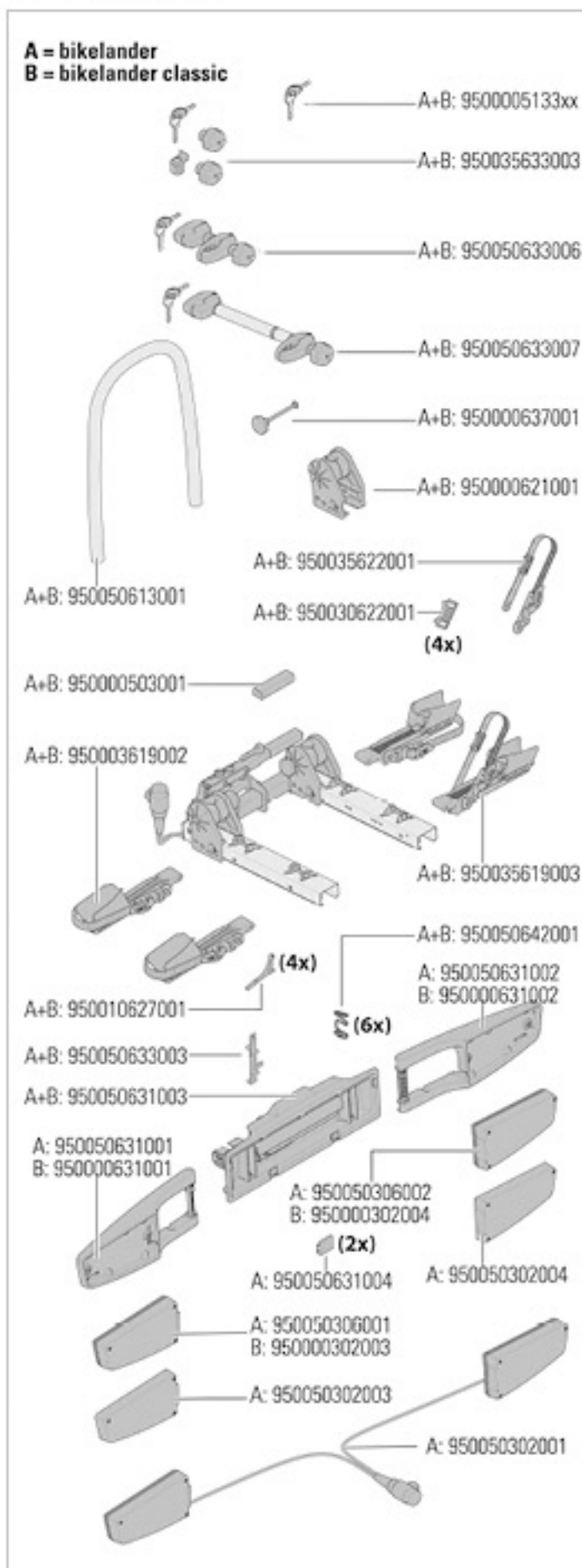

## 12. Product warranty

Dear customer:

Having purchased this Westfalia product, you have selected a high quality standard.

For this reason, Westfalia Automotive GmbH grants you a product warranty of five (5) years under the conditions given in this declaration.

This product warranty is valid under the following conditions that

- your regular residency is in Europe,
- this Westfalia product has been manufactured by Westfalia Automotive GmbH and was sold as a new product and
- you have inspected this Westfalia product upon purchase for defects and reported any detected defects to the dealer from whom you have purchased the Westfalia product.

In so far as the conditions listed in this declaration for a product warranty have been met, you are authorised to make claims towards Westfalia Automotive GmbH if

- construction, material or manufacturing faults that are the responsibility of Westfalia Automotive GmbH significantly impair the normal use of this Westfalia product and
- use impairment because of insufficient servicing, improper and nonintended use or special environmental influences or unusual operational conditions can be ruled out and
- you permit Westfalia Automotive GmbH to inspect this Westfalia product on site.

To satisfy your claims made valid by this product warranty, Westfalia Automotive GmbH may at its discretion

- either repair faulty Westfalia products or supply a replacement or
- replace the current value of the Westfalia product in cash (current value is original purchase price depreciated by 15 % for each year started after the purchase).

Your claims for this product warranty expire within one year after the claim has been reported by you to Westfalia Automotive GmbH. The duration of the product warranty of five (5) years is a terminating duration that begins with the purchase of this Westfalia product and is not extended by the providing of the warranty measures.

There are no further claims from this product warranty. As long as Westfalia Automotive GmbH has not culpably injured life, body or health or violated other obligations from this product warranty with premeditation or gross negligence, no further claims for damages in particular can be claimed against Westfalia Automotive GmbH.

Your contractual claims towards the dealer from whom you purchased this Westfalia product, in particular due to material defects, are not affected by this product warranty.



Westfalia-Automotive GmbH  
Am Sandberg 45  
33378 Rheda-Wiedenbrück

[www.westfalia-automotive.com](http://www.westfalia-automotive.com)  
[www.bikeland.de](http://www.bikeland.de)  
[www.bikeland.eu](http://www.bikeland.eu)

