



These Instruction Sheets contain **IMPORTANT** safety information. Please read and keep for future reference.

2 Bike Trunk Mount Carrier

1392900G

Before Using Your Bike Carrier

The user must read and understand these Instruction Sheets and the Warranty.

Installation is the end user's responsibility and beyond Cequent Consumer Products control. Therefore, Cequent Consumer Products exclusively limits its Warranty to the repair or replacement of a defective product. Damage to your vehicle, your cargo or any person or property is excluded.

- ⚠️ Your Bike Carrier must be inspected for signs of wear, corrosion and fatigue before each use.
- ⚠️ Make sure your Bike Carrier is secure before every trip. Check at each stop to ensure your Bike Carrier is secure.
- ⚠️ Remove your Bike Carrier when not in use and before entering automatic car washes.
- ⚠️ ALWAYS obey all posted speed limits and be aware of traffic conditions. Adapt your speed to the conditions of the road and the load being carried.
- ⚠️ Check local and state laws governing projection of objects beyond the perimeter of a vehicle.
- ⚠️ Do not use your Bike Carrier for purposes other than those for which it was designed. Do not exceed your Bike Carrier's rated capacity. The capacity is 70 lbs.
- ⚠️ Your Bike Carrier will not prevent property damage that may result from improper loading, securing, or driving.
- ⚠️ Do not attempt to drill, weld, or modify your Bike Carrier or any of the system components.
- ⚠️ Designed for sedans, hatchbacks and SUVs with slanted profiles. The arms of the bike rack MUST be angled upward. Do NOT use if arms angle downward.

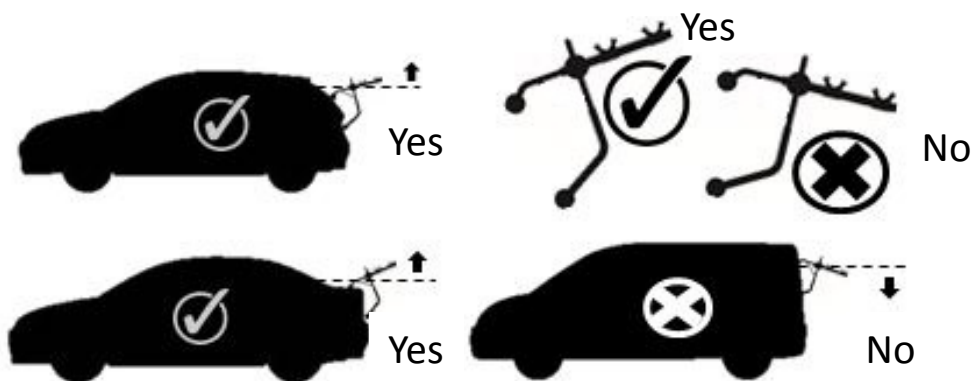

CEQUENT™
CONSUMER PRODUCTS

Parts List

Part	Description	Quantity
A	Middle Support	1
B	Bottom Support	1
C	Top Support	1
D	Support Arm	2
E	Buckle Assembly	6
F	¼"-20 Hex Head Cap Screw	2
G	¼"-20 Locknut	2
H	5/16"-18 Hex Head Cap Screw	2
I	5-16"-18 Locknut	2
J	Outer Support (marked "A")	2
K	Inner Support (marked "B")	2
L	Top Trunk Strap	2
M	Bottom/Side Trunk Straps	4

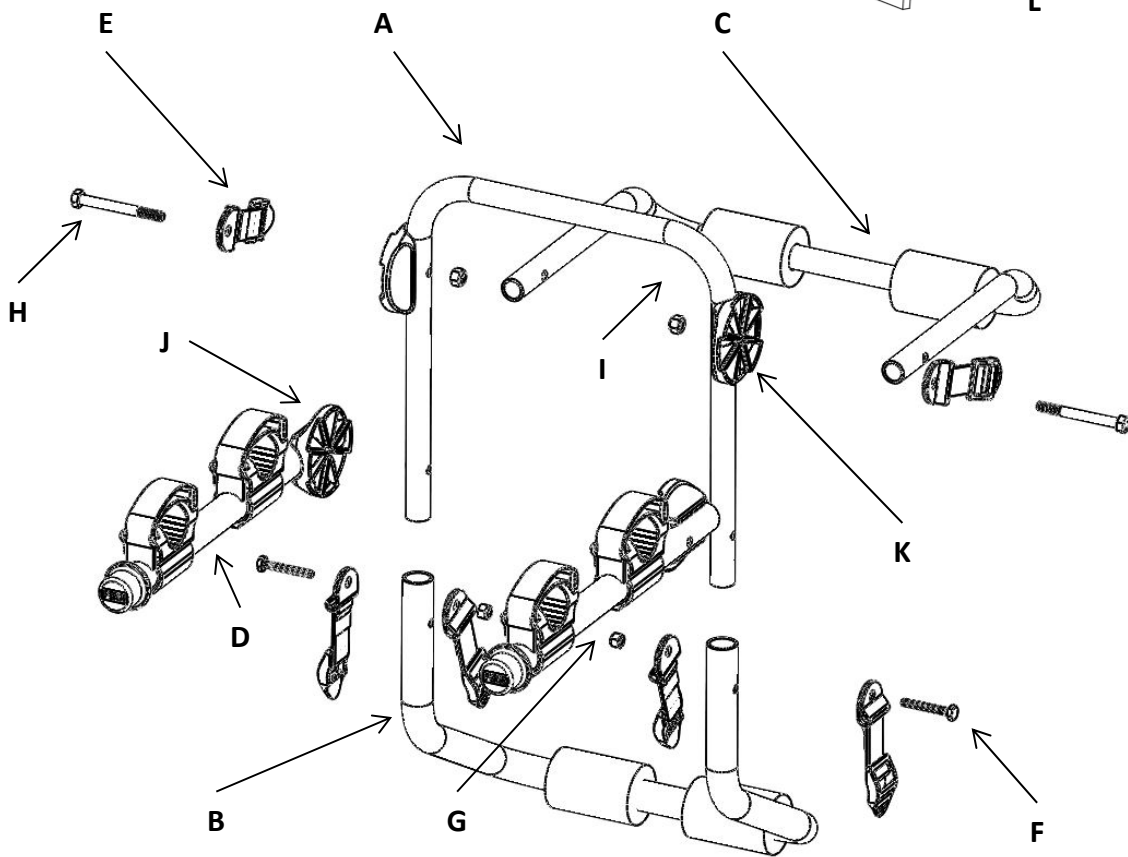
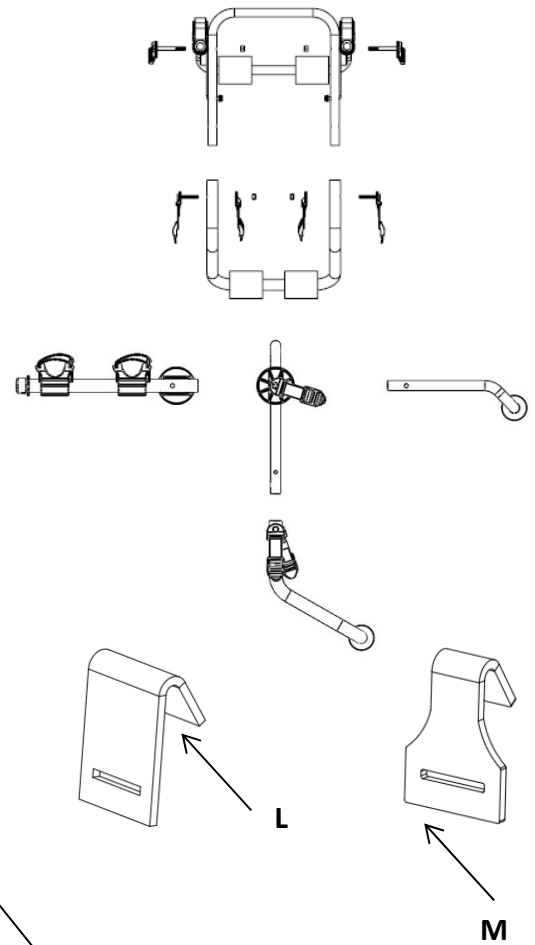

Assembly Instructions

Tools required for assembly: (2) Adjustable wrench and/or (2) 7/16" wrenches and (2) 1/2" wrenches

Step 1: Remove all parts from box and make sure all parts out of the box are undamaged.

Step 2: Assemble Main Frame

- A. Slide Middle Support into Bottom Support so that the through holes are aligned. (Fig. 1)
- B. Slide Buckle Assembly onto the 1/4"-20 Hex Head Cap Screw (smaller screw) and insert the screw through the through hole in the Main Frame. Then slide another buckle assembly on the other side. (Fig. 1)
- C. Thread the locknut onto the screw and tighten using two adjustable wrenches. Repeat for the other side. The Main Frame should appear as shown on the right. (Fig. 2)

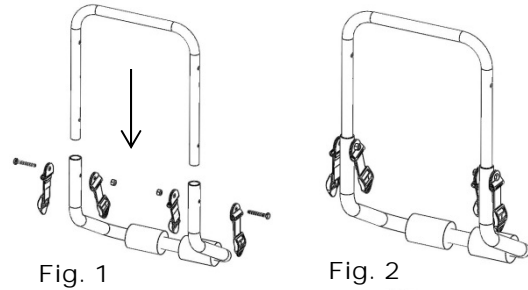

Fig. 1

Fig. 2

Step 3: Assemble Support Arm Frame

- A. Attach each Inner Support (marked with a "B") to middle support tube as shown with through holes lined up. (Fig. 3). Attach the outer supports (marked with an "A") to each Support Arm. Slide Top Support into one of the Support Arms so that the through holes are aligned. Slide Buckle Assembly onto the 5/16"-18 Hex Head Cap Screw (larger screw) and insert the screw through the through hole in the Support Arm Frame, Supports and the top Main Frame hole. (Fig. 3/4) Repeat for other side. (Fig. 3/4)
- B. Thread the locknut onto the screw and tighten securely. Note; the Inner and Outer Supports should be fully mated (no gaps). (Fig. 4b)

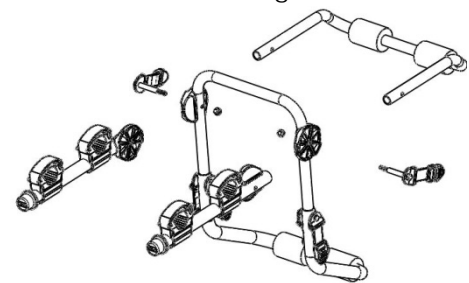

Fig. 3

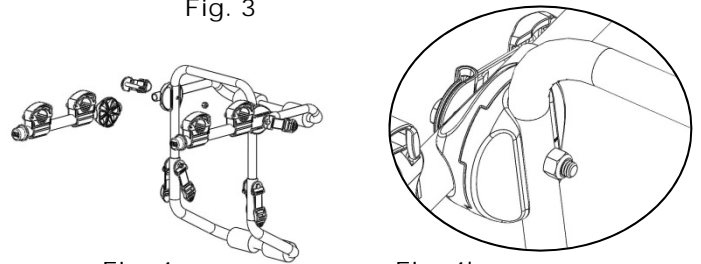

Fig. 4

Fig. 4b

Step 4: To Fold Bike Rack For Storage

- A. Loosen the 5/16" locknuts on the Middle Support Frame. As the locknuts are loosened, the Outer and Inner Supports should begin to separate as shown in Fig 5.
- B. Once Outer and Inner Supports are separated, swing Support Arms downward to fold. (Fig 5/6)
- C. Re-tighten locknut and make sure Outer and Inner Supports are mated.

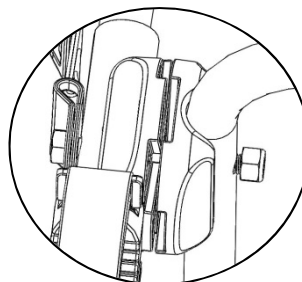

Fig. 5

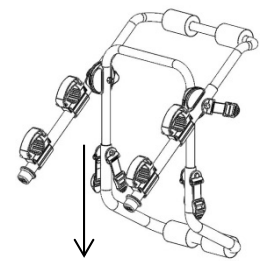

Fig. 5b

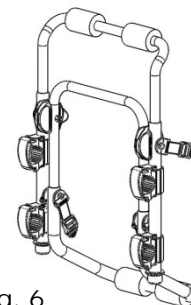

Fig. 6

Mounting Bike Carrier to Vehicle Instructions

Step 5: Thread Trunk Straps into Buckles

- A. Thread a trunk strap into a buckle, as pictured below. Repeat for remaining buckles. (Fig. 7)
- B. NOTE: The Bottom/Side Straps are to be threaded on the lower Buckle Assemblies. The Top Hooks (Figure 8) and Bottom / Side Hooks (Figure 9) are shown below.

Step 6: Mount Bike Carrier

- A. Wipe away dirt on vehicle and carrier pads.
- B. Pop the trunk or hatch so there is a slight gap between trunk lid and car frame.
- C. Position the Bike Carrier so that it is centered side to side and so that the support arms are angled upward.

CAUTION: The arms of the bike rack MUST angle upward. Do NOT use if arms angle downward. See Figure 10.

- D. Attach the top hooks to the top of the trunk. Slightly tighten straps.

NOTICE: Do not attach hooks to glass or plastic.

- E. Attach the bottom hooks to the bottom of the trunk. Slightly tighten straps. Attach the side hooks to the sides of the trunk. Close the trunk slowly. The lower straps may also be attached to edge underneath the bumper as long as it is not plastic.
- F. Now tighten top straps ensuring that the angle of the support arms are slightly upward. Finish by tightening the bottom/side straps.
- G. Check security of Bike Carrier and straps.

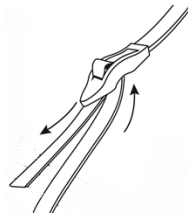

Fig. 7

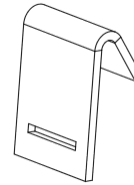

Fig. 8

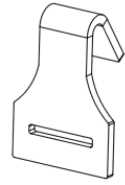

Fig. 9

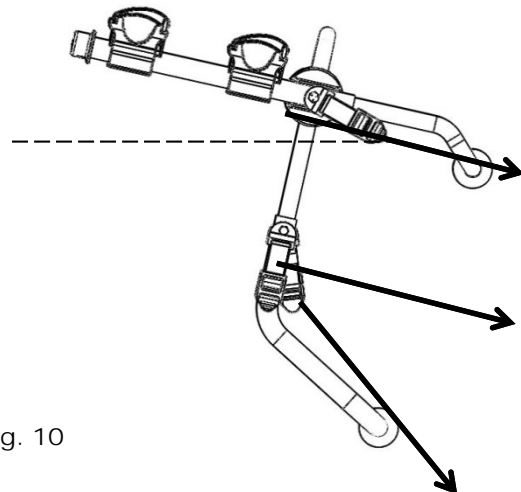
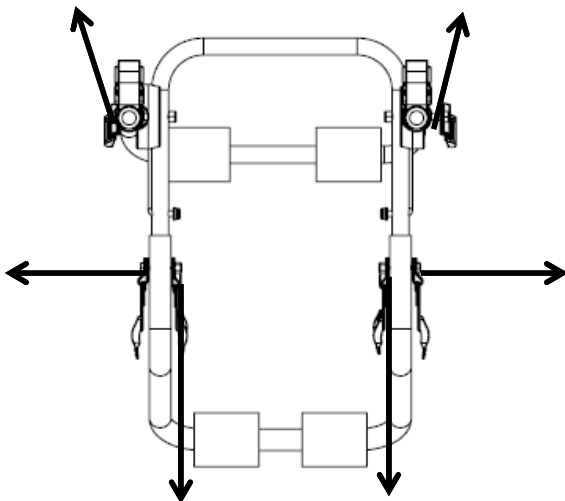

Fig. 10

Mounting Bikes to Bike Carrier Instructions

Step 1: Mount Bikes to Bike Carrier

- A. Load first bike on the Bike Carrier so that the frame of the bike rests on the cradles closest to the vehicle. If only loading one bike use cradles closest to the vehicle. If loading a mountain bike or women's bike, it is recommended to purchase a bike carrier adapter (sold separately) to accommodate for unique frame geometry.
- B. Position the bike so that the weight is evenly spread across the two cradles. The bike will slightly rest against the bottom of the bike carrier. Run the cradle strap over the bike frame, through the cradle strap buckle and back over the frame.
- C. For second bike, load bike in the opposite direction and repeat steps.
- D. Retighten bike carrier straps and check security of the Bike Carrier and bikes by checking trunk straps and cradle straps.
- E. Secure front bike tires with additional straps.

NOTICE: Keep bike tires away from vehicle exhaust pipe. Make sure bike pedals are not touching the vehicle.

CAUTION: The arms of the bike rack MUST be angled upward. Do NOT use if arms angle downward. See Figure 10.

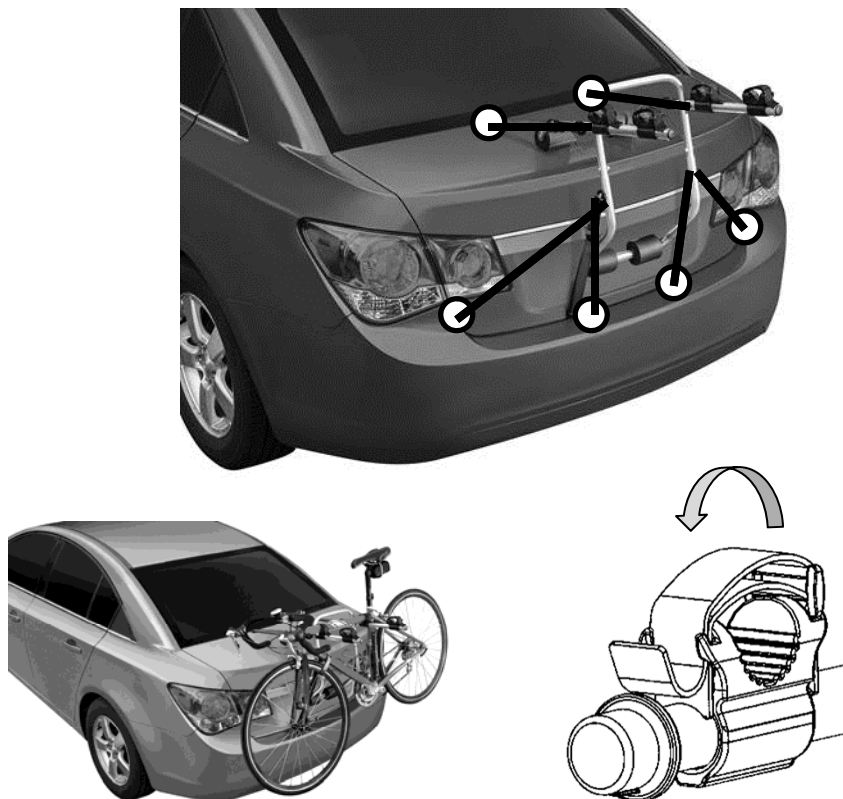

Before Driving

⚠️WARNING

To Prevent Serious Injury or Death:

- **INSPECT** for signs of wear, corrosion, and fatigue **BEFORE** each use. **DO NOT** use if bent or deformed.
- **DO NOT EXCEED** the 70 lb. (32 kg) capacity of the Bike Carrier.

While Driving

⚠️WARNING

To Prevent Serious Injury, Death and Property Damage:

- **REDUCE YOUR SPEED.** Your vehicle can handle differently when transporting cargo on the trunk.
- **ALWAYS** obey all posted speed limits and be aware of traffic conditions.
- **FREQUENTLY** check your Bike Carrier and that the bikes are secure. Bikes can shift or your Bike Carrier can loosen during travel. Readjust as needed. If movement continues, stop use.

After Driving

⚠️WARNING

To Prevent Serious Injury and Property Damage:

- **ALWAYS** unload bikes before removing your Bike Carrier from trunk.
- **ALWAYS** remove your Bike Carrier when not in use.

THIS WARNING IS GIVEN IN COMPLIANCE WITH CALIFORNIA PROPOSITION 65

WARNING: This product contains chemicals known to the state of California to cause cancer, birth defects or other reproductive harm.